

# plus One<sup>®</sup>

kegel trainer

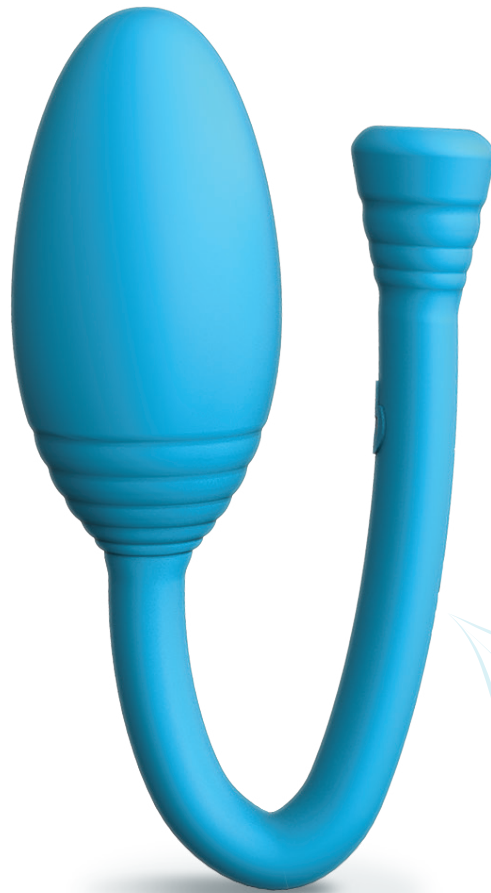

instruction manual



## product overview

### 1) power button:

To turn the trainer on, press and hold the trainer power button for 3 seconds. When turning the trainer on, do not squeeze the Kegel Trainer until the remote is connected. To turn the remote on, press and hold the remote power button for 3 seconds. Both LEDs will flash like a heartbeat to indicate the products are on and ready to connect. Once both products are on and flashing, the trainer and remote will automatically connect. Once connected, both LEDs will turn solid. Click the power button on either the kegel trainer or the remote to toggle through the following settings:

1. Training mode (kegel trainer does not vibrate)
2. Vibration setting 1
3. Vibration setting 2
4. Vibration setting 3
5. Vibration setting 4
6. Vibration setting 5

After the 6th setting, the product will toggle back to setting #1: training mode. To turn the trainer and remote off, press and hold each power button for 3 seconds.

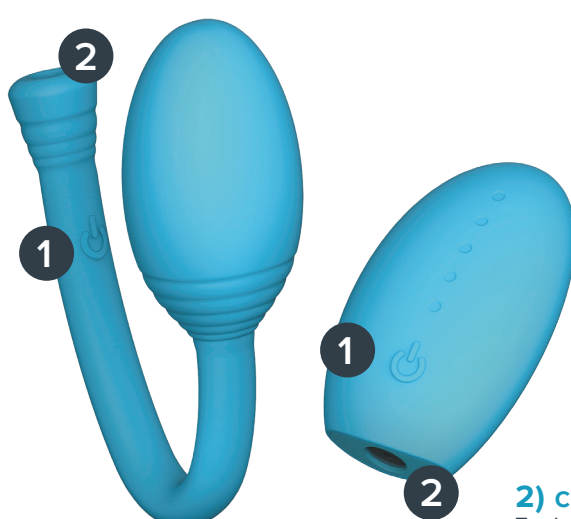

### 2) charging port:

To charge both products simultaneously, attach the twin-headed magnetic charging cable to the charging contacts on the trainer and remote.

## how to charge

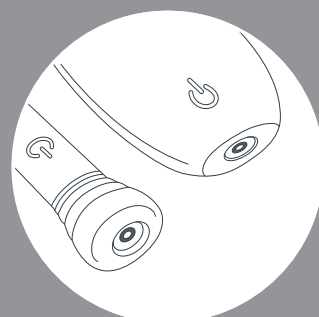

1. The charging contacts are the small metal circles located at the bottom of the remote and at the end of the trainer's tail.

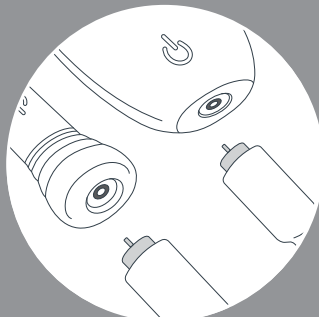

2. Line up the magnetic charging heads with the contacts on the trainer and remote.

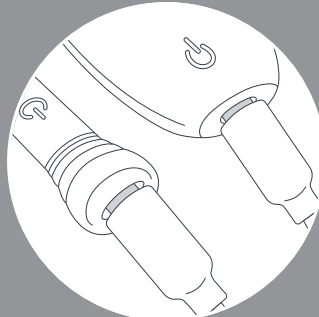

3. The cables will magnetically attach themselves into place. The power button LED lights will pulsate slowly to indicate charging.

### special instructions:

Do not turn on while charging and/or cleaning. The power button lights will pulsate slowly while charging and turn solid when fully charged. Low battery alert: each power button light will flash rapidly when battery is running low. Use only with 5-volt USB wall adapter (standard mobile phone charger). Allow 60 minutes for a full charge. Use water-based lubricant only.

### cleaning:

Clean thoroughly with mild soap and warm water, before and after each use.

### storage:

Store in a cool, dry place separate from other sexual wellness devices; sexual wellness devices of different material can damage each other if left in contact.

### quality:

This product is manufactured using body-safe silicone that is harmless to the human body; free from phthalates, BPA and latex.

### warnings:

Discontinue use if there is any discomfort for you or your partner. Do not expose device to water while charging.

## how to insert & use

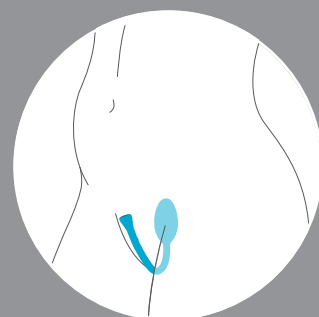

Insert the trainer by gently sliding the larger, rounded end into the vagina until it sits comfortably. The tail of the trainer should remain outside the body, curling up towards the belly button.

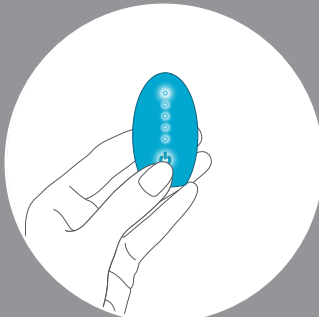

Once the product is inserted, on, and in training mode, perform your pelvic exercises. If the exercises are performed correctly, the indicator lights on the remote will illuminate. The stronger the squeeze, the more lights will illuminate.

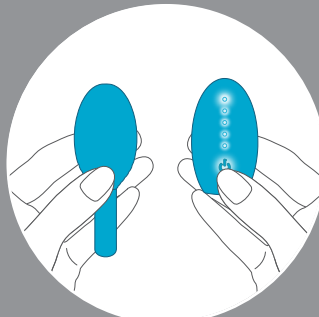

If the lights do not illuminate, reposition the trainer internally and/or make sure the trainer is connected to the remote by gently squeezing the trainer in your hand.

## understanding your pelvic floor

Your pelvic floor is a group of muscles that stretches like a hammock from your pubic bone to your tailbone. It supports internal organs such as your uterus, colon, and bladder. If your pelvic floor is weak, you may experience frequent trips to the bathroom, lower back aches, urine leaks, and a decline in intimate sensation. By using the plusOne® kegel trainer, you can work your way to a strong and healthy pelvic floor.

### how to perform a kegel:

The muscles you use to stop urinating mid-flow are your pelvic floor muscles. Kegels are performed by engaging the same muscles in the same way. Focus on lifting the muscle upward while squeezing the vaginal opening closed.

### strength training:

Start by squeezing as hard as possible for 5 seconds and then relaxing for 5 seconds. Repeat this 5 times. Perform this exercise up to 3 times a day.

### endurance training:

Gently squeeze and hold for as long as possible. Maintain the same squeeze strength by keeping the indicator lights on the remote at the same level, then relax. Perform this exercise up to 3 times a day.

### control training:

Squeeze until the first indicator light illuminates. Hold at this level for 5 seconds, trying to keep the indicator light still. Relax for 10 seconds. Then squeeze until the first and second indicator lights illuminate. Hold at this level for 5 seconds, trying to keep the indicator lights still. Relax for 10 seconds. Repeat, adding an additional indicator light each time. Perform this exercise up to 3 times a day.

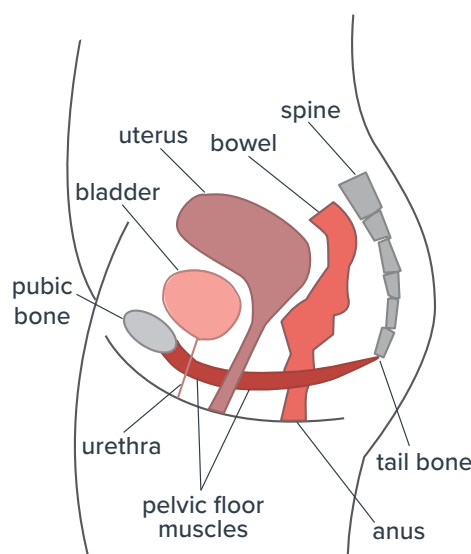

### FCC COMPLIANCE STATEMENT:

This device complies with part 15 of the FCC Rules. Operation is subject to the following two conditions: (1) This device may not cause harmful interference, and (2) this device must accept any interference received, including interference that may cause undesired operation.

Note: This equipment has been tested and found to comply with the limits for a Class B digital device, pursuant to Part 15 of the FCC Rules. These limits are designed to provide reasonable protection against harmful interference in a residential installation. This equipment generates, uses and can radiate radio frequency energy and, if not installed and used in accordance with the instructions, may cause harmful interference to radio communications.

However, there is no guarantee that interference will not occur in a particular installation. If this equipment does cause harmful interference to radio or television reception, which can be determined by turning the equipment off and on, the user is encouraged to try to correct the interference by one or more of the following measures:

- Reorient or relocate the receiving antenna.
- Increase the separation between the equipment and receiver.
- Connect the equipment into an outlet on a circuit different from that to which the receiver is connected.
- Consult the dealer or an experienced radio/TV technician for help.

Warning: Changes or modifications to this unit not expressly approved by the part responsible for compliance could void the user's authority to operate the equipment.

### FCC Radiation Exposure Statement

The device has been evaluated to meet general RF exposure requirement. The device can be used in portable exposure condition without restriction.

The battery shall be disposed in accordance with the local laws and regulations. If possible please recycle it. Users shall not take out or replace the battery by themselves; doing so may damage the product.

### two year limited warranty:

Your new plusOne® products carry a warranty against manufacturing defects for two years from the date of original purchase. plusOne® will, at our option and upon submission of a valid proof of purchase within the warranty period, repair or replace the product free of charge.

For assistance or for issues related to performance, damages, warranty, regular maintenance or customer feedback please contact plusOne® toll free at (800) 514-2546, Monday – Friday from 8:30 am until 5:30pm EST or email us at info@myplusOne.com